



# NATIONAL CERTIFIED TESTING LABORATORIES

FIVE LEIGH DRIVE • YORK, PENNSYLVANIA 17406 • TELEPHONE (717) 846-1200  
FAX (717) 767-4100  
www.nctlinc.com

**AAMA/WDMA/CSA 101/I.S.2/A440-08**

## TEST REPORT SUMMARY

**Rendered to:**

**NEON ENERGY  
230 Park Avenue 10<sup>th</sup> Floor  
New York, NY 10169**

**PRODUCT TYPE: Fixed Lite**

**SERIES/ MODEL: "Fixed"**

Title	Summary of Results
Primary Product Designator AAMA/WDMA/CSA 101/I.S.2/A440-08	Class CW-PG30: Size tested 1524 x 2515 mm (60 x 99 in) - Type FW
Design Pressure	±1440 Pa (±30.0 psf)
Air Infiltration	0.1 L/s/m <sup>2</sup> (<0.01 cfm/ft <sup>2</sup> )
Water Penetration Resistance Test Pressure	440 Pa (9.0 psf)
Uniform Load Structural Test Pressure	±2160 Pa (±45.0 psf)
Forced Entry Resistance	ASTM F588-07 - Grade 10 Pass

Test Completed: 08/03/16  
Revision Date: 10/18/16

Reference must be made to Report No. NCTL-110-19251-2 dated 08/05/16 for complete test specimen description and data.

**For National Certified Testing Laboratories**

DIGITAL SIGNATURE

Jay Leader  
Technician



# ***NATIONAL CERTIFIED TESTING LABORATORIES***

FIVE LEIGH DRIVE • YORK, PENNSYLVANIA 17406 • TELEPHONE (717) 846-1200  
FAX (717) 767-4100  
www.nctlinc.com

## **AAMA/WDMA/CSA 101/I.S.2/A440-08**

### **STRUCTURAL TEST REPORT**

## **NCTL-110-19251-2**

REPORT TO:

NEON ENERGY  
230 PARK AVENUE 10<sup>TH</sup> FLOOR  
NEW YORK, NY 10169

REPORT NUMBER: NCTL-110-19251-2

REPORT DATE: 08/05/16

REVISION DATE: 10/18/16

**PRODUCT TYPE: FIXED LITE**

**SERIES/ MODEL: "FIXED"**



# NATIONAL CERTIFIED TESTING LABORATORIES

FIVE LEIGH DRIVE • YORK, PENNSYLVANIA 17406 • TELEPHONE (717) 846-1200  
FAX (717) 767-4100  
www.nctlinc.com

**Report Number** NCTL-110-19251-2

**Report Date** 08/05/16  
**Revision Date** 10/18/16

**Report To** Neon Energy  
230 Park Avenue 10<sup>th</sup> Floor  
New York, NY 10169

**Date Testing Started** 07/18/16  
**Date Testing Completed** 08/03/16

**Specification** AAMA/WDMA/CSA 101/I.S.2/A440-08  
NAFS North American Fenestration Standard/Specification for windows,  
doors, and skylights

**Performance Results** AAMA/WDMA/CSA 101/I.S.2/A440-08  
Class CW-PG30: Size tested 1524 x 2515 mm (60 x 99 in)-Type FW

## ***Description of Specimen Tested***

Note: All dimensions are in the order (Width x Height x Thickness) unless otherwise noted.

**Model/ Series** Fixed

**Configuration** Fixed Lite

**Frame Size** Overall  
1524 mm x 2515 mm (60" x 99")

**Viewing Area** 1422 mm x 2413 mm (56" x 95")

**Frame Type** Extruded aluminum with polyamide thermal break

**Joint Construction** Frame  
Mitered, with epoxied with aluminum staked-in-place and epoxied corner gusset

**Glazing Components**

Overall 22.23 mm (0.875") nominal

Glass Thickness (1) Lite of 6 mm (0.230") nominal tempered glass to the exterior and (1) lite of 6 mm (0.230") nominal annealed glass to the interior

Spacer Type/Size 10.54 mm (0.415") Desiccant-filled stainless steel spacer (Type SS-D)

Glazing System Interior glazed against a multi-fin vinyl glazing gasket and a snap-in extruded aluminum glazing bead with a flexible vinyl wedge gasket

**Weatherstrip**

Type Bulb-vinyl gasket

Location Sill

**Operating Hardware** No operating hardware employed

**Auxiliary** No auxiliary items employed

**Reinforcement** No reinforcement employed

**Weep Description**

Size 25.4 mm (1") wide by 7.95 mm (0.313") high with plastic weep cover  
 Location 136.53 mm (5.375") from each end and midspan of the exterior sill face

**Interior/ Exterior Surface Finish**

White painted aluminum

**Sealant**

Location 152.4 mm (6") High heel bead employed at bottom of jambs  
 Material Silicone

**Insect Screen**

No screen employed

**Installation Method**

The window was installed in a 50.8 mm x 254 mm (2" x 10") spruce-pine-fir lumber test buck and secured with (1) #8 x 38.1 mm (1.5") pan head screw located at 50.8 mm (2") and 559 mm (22") from each end of the sill and head; 50.8 mm (2"), 559 mm (22"), 1067 mm (42"), 1702 mm (67"), 2197 mm (86.5") and 2464 mm (97") from the bottom of each jamb. The exterior perimeter was sealed with silicone sealant.

**Test Results - AAMA/WDMA/CSA 101/I.S.2/A440-2008**

Paragraph  
5.3.2.1/ 9.3.2

Test  
Air Leakage Resistance  
ASTM E283-04(12)

The tested specimen meets or exceeds the performance levels specified in AAMA/WDMA/CSA 101/I.S.2/A440-2008 for air infiltration at 75 Pa (1.6 psf).

Maximum Allowable	=	1.5 L/s/m <sup>2</sup> (0.3 cfm/ft <sup>2</sup> )
Extraneous Air Leakage	=	0.93 L/s (1.97 cfm)
Total Air Leakage	=	1.17 L/s (2.47 cfm)
Air Infiltration Rate	=	0.1 L/s/m <sup>2</sup> (<0.01 cfm/ft <sup>2</sup> )

Paragraph  
5.3.3/ 9.3.3

Test  
Water Penetration Resistance  
ASTM E547-00(09)

3.4 L/ (min • m<sup>2</sup>) (5.0 gph/ft<sup>2</sup>)

No Leakage after 4 cycles of 5 minutes at 440 Pa (9.0 psf)

**NOTE:** Tested without insect screen

Paragraph  
5.3.4.2

Test  
Uniform Load Deflection at Design Pressure  
ASTM E330-14

No damage after positive	1440 Pa (30.0 psf) held for 10 seconds
No damage after negative	1440 Pa (30.0 psf) held for 10 seconds
Measured Deflection <sup>Positive</sup>	= 0.94 mm (0.037 inches)
Measured Deflection <sup>Negative</sup>	= 1.52 mm (0.060 inches)
Maximum Allowed (L/175)	= 14.38 mm (0.566 inches)

Paragraph  
5.3.4.3

Test  
Uniform Load Structural Test  
ASTM E330-14

No damage after positive      2160 Pa (45.0 psf) held for 10 seconds  
 No damage after negative      2160 Pa (45.0 psf) held for 10 seconds

Measured Permanent Set <sub>Positive</sub> = 0.28 mm (0.011 inches)  
 Measured Permanent Set <sub>Negative</sub> = 0.74 mm (0.029 inches)  
 Maximum Allowed (0.3%)      = 7.54 mm (0.297 inches)

**NOTE:** Deflection and Permanent Set measurements taken on the jamb over a 2515 mm (99") span.

Paragraph  
5.3.5/ 9.3.5

Test  
Forced Entry Resistance  
ASTM F588-07

Type D Window Assembly/ Grade 10: = Pass

Test  
Disassembly                      = No Entry  
 Sash Manipulation              = No Entry

**NOTE:** 1. T1 = 5 minutes, L1 = 667 N (150 lbf), L2 = 333 N (75 lbf), L3 = 111 N (25 lbf)  
 2. Loads were held for 60 seconds.

This test report was prepared by National Certified Testing Laboratory (NCTL), for the exclusive use of the above named client and it does not constitute certification of this product. The results are for the particular specimen tested and do not imply the quality of similar or identical products manufactured or installed from specifications identical to the tested product. The test specimen was supplied to NCTL by the above named client. No conclusions of any kind regarding the adequacy or inadequacy of the glass in the test specimen are to be drawn from the ASTM E330 test. Forced entry resistance test equipment used is in compliance with Section 7 of the ASTM F588-07 test method. Foam tape is mounted to the perimeter of the test buck prior to clamping to the test wall. It is the assertion of this laboratory that any film employed during testing does not affect measurement values. NCTL is a testing lab and assumes that all information provided by the client is accurate and does not guarantee or warranty any product tested or installed. The results in this report are actual tested values and are applicable to the specimen tested only, using the components and construction methods described herein.

Detailed drawings were available for laboratory records and compared to the test specimen at the time of this report. Component drawings were reviewed for product verification. The bill of materials contains details with any deviations noted. Ambient conditions during the referenced testing are available upon request. A copy of this report along with representative sections of the test specimen will be retained per applicable requirements by NCTL. This report does not constitute certification or approval of the product, which may only be granted by a certification program validator or recognized approval entity. All tests were conducted in full compliance with the referenced specifications and/or test methods. Tests were performed in the order set forth by the applicable standard or specification. This report is the joint property of National Certified Testing Laboratories Inc. and the Client to whom it is issued. Permission to reproduce this report by anyone other than National Certified Testing Laboratories Inc and the Client must be granted in writing by both of the above parties. This report may not be reproduced, except its entirety, without the written consent of NCTL.

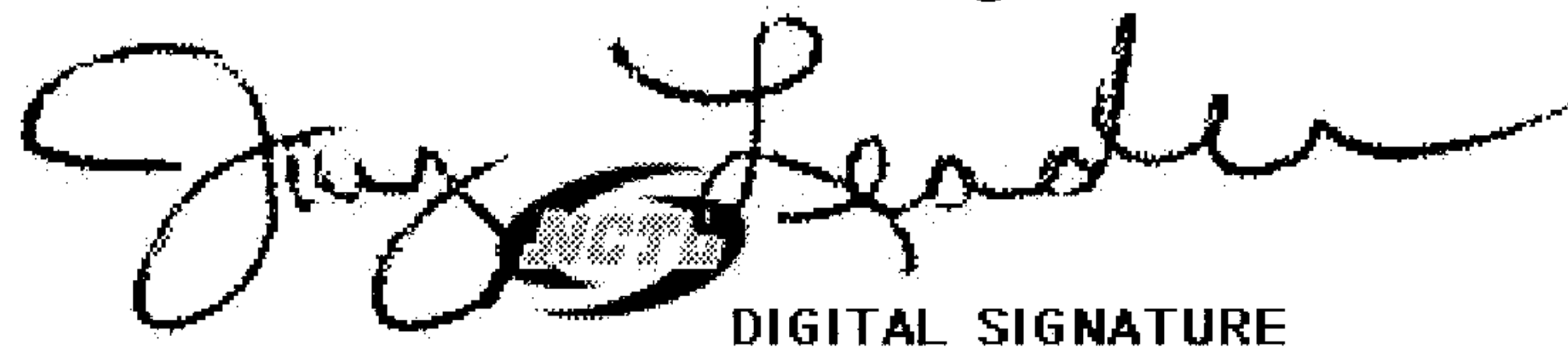
**National Certified Testing Laboratories**  
DIGITAL SIGNATURE

Jay Leader  
Technician

  
DIGITAL  
SIGNATURE

Robert H. Zeiders, P.E.  
Vice-President Engineering & Quality

NJL/ dro

Attachments

Appendix A – Revision Summary

Appendix B – Drawings

## Appendix A

### Revision Log

<u>Identification</u>	<u>Date</u>	<u>Page &amp; Revision</u>
Original Issue	08/05/16	Not Applicable
Revision 1	10/18/16	Corrected page 3 to show CW-PG30

## **Appendix B**

### **Drawings**

Component Drawings, with Applicable Part Numbers, Manufacturing and Modeling Details, were reviewed (as submitted) for Product Verification. Detailed assembly drawings showing wall thicknesses of all members, corner construction and hardware application are on file and have been compared to the test sample submitted.  
(Reference: NCTL-110-19251-2)

See Attached Documentation;  
any deviations noted.

Note: The above referenced component drawings (if applicable) along with representative sections of the test specimen will be retained by NCTL per applicable retention requirements. This testing facility assumes that all information provided by the client is accurate.

**Description of test specimen No 5 & No 6:**

Product	Fixed window
Manufacturer	Alco Hellas S.A.
Date of manufacture	3/6/2016
System	Ultra 2016 Opening System
Type of opening / Opening directions	No opening
Frame material	Aluminum profiles with thermal break
Overall frame dimensions (WxH)	5' 0" x 8' 3"
<b>Frame member</b>	Profile No TVO 921
Frame joint	mitred, compressed and bonded with corner connection No GS 56-80 and GS 152-186
<b>Infill panel</b>	Glass Unit
Configuration	from inside to outside: 15/64" glass, 35/64" airspace, 15/64" glass
<b>Incorporation of infill panel</b>	
<b>Glazing gasket</b>	
<u>Internal:</u>	
Material	Sealing material – EPDM
Item No	P3
Corner design	mitred and bonded
<u>Glazing bead</u>	Profile No VO 41
Corner design	butt-jointed
Fixing	clamped
<u>External:</u>	
Material	Sealing material – EPDM
Item No	AVO-03
Corner design	mitred and bonded

TEST SPECIMEN COMPLIES  
WITH THESE DETAILS.  
ANY DEVIATION IS NOTED  
REPORT NO. NCTL-110- 19251-2  
TEST DATE 8/3/16

**HORIZONTAL SECTION A-A' & VERTICAL SECTION BB'**

**KA. 1:1**

**TEST SPECIMENT No 5 & No 6**

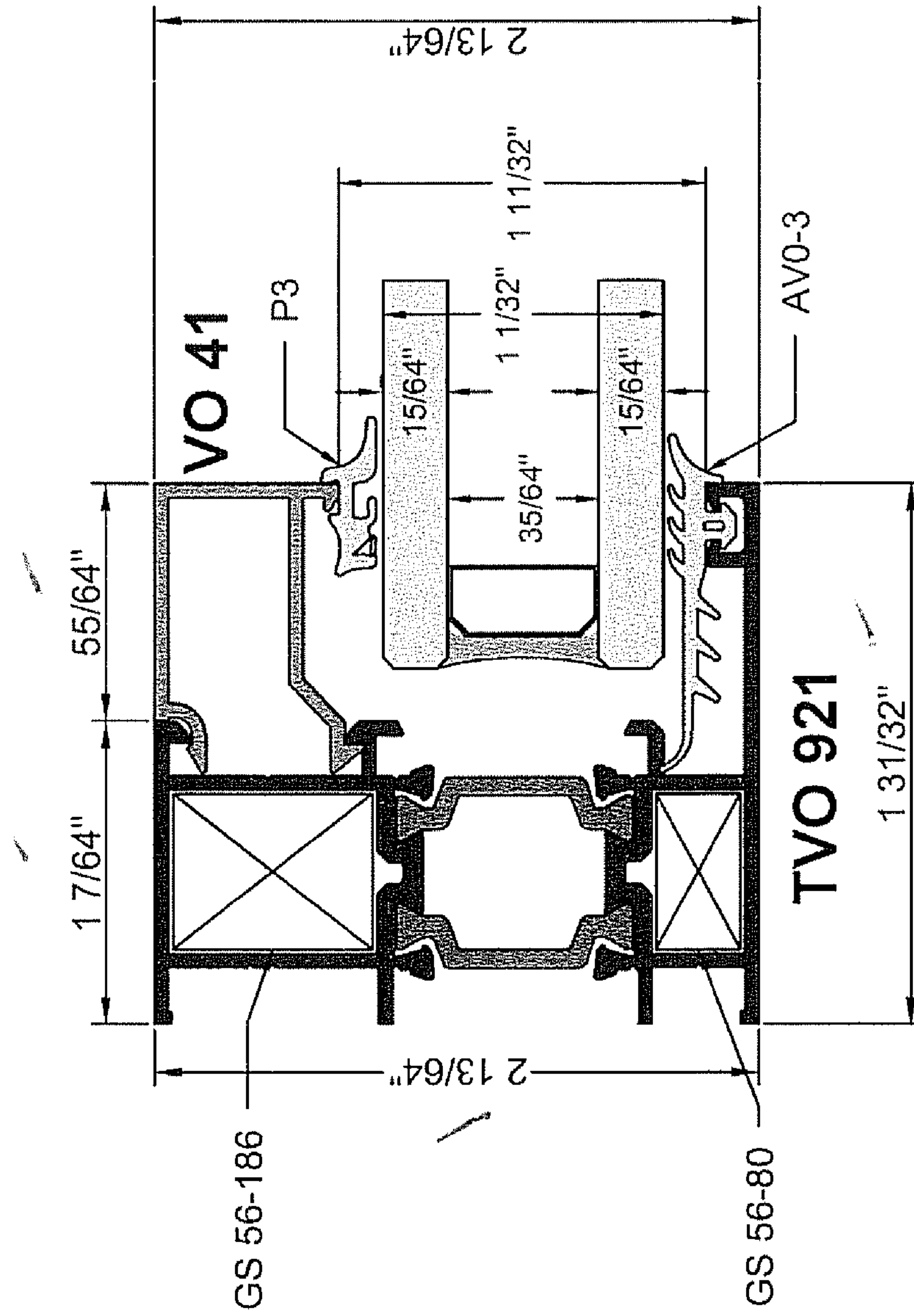
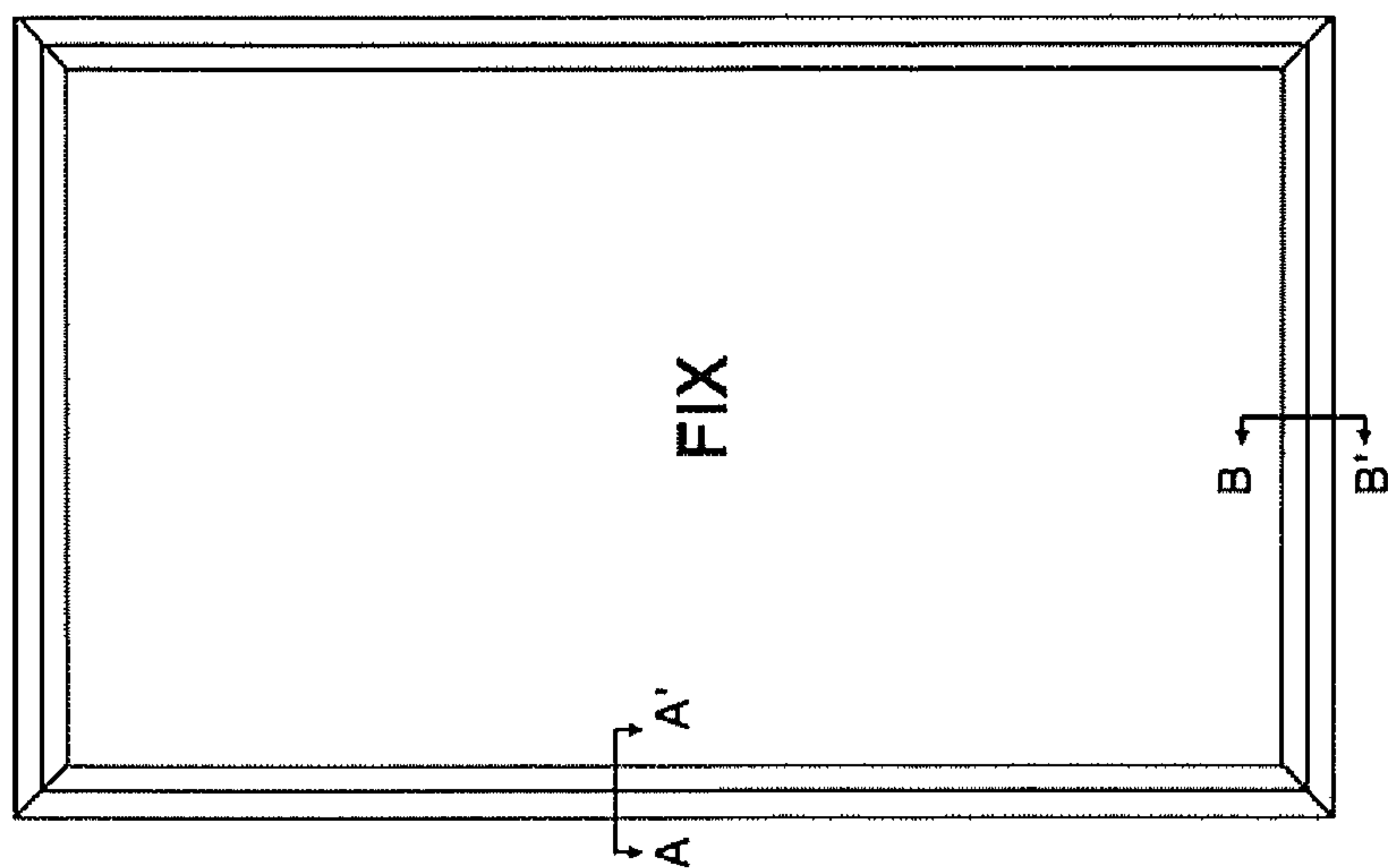

TEST SPECIMEN COMPLIES  
 WITH THESE DETAILS.  
 ANY DEVIATION IS NOTED  
 REPORT NO. NCTL-110-19251-2  
 TEST DATE 8/3/16

## Jon Martini

---

**From:** Jon Hill  
**Sent:** Tuesday, November 08, 2016 5:02 PM  
**To:** Alysha Hill; Jon Martini  
**Subject:** FW: RE: KEYSTONE

OK, Aly you'll need to void the invoice for the second location and complete the O-Sht for Heywood Investments USA, Inc. They also have several structural reports from NCTL ready to be logged.

Jon we'll need to get these several AWS certs for this new customer done by next week.

Jon

---

**From:** Ανδρέας Γεωργακής [mailto:andreas.georgakis@gmail.com]  
**Sent:** Tuesday, November 08, 2016 4:30 PM  
**To:** Jon Hill  
**Cc:** vallas@neon-energy.com; a.georgakis@neon-energy.com; Alysha Hill; ΠΟΣΤΑΝΤΖΗ ΔΕΣΠΟΙΝΑ  
**Subject:** Fwd: RE: KEYSTONE

Hello Jon,

This is my private email, my Neon email does not work unfortunately for some reason. Please find my answers to your questions below:

\*Yes, please proceed with company name "Heywood Investment USA Inc."

\*Yes, there will be just ONE manufacturing location finally. Please ignore to what was told on the phone. The reason for that is to move one with the procedures the fastest possible. Later on, in case we include the second location (when the capacity of work grows up) we shall make an additional agreement for that as well.

I reckon we are clear now.

Please inform us whether you have any queries during the certification of the lab reports. We will be happy to assist at any time needed.

Many thanks in advance,

Best Regards,  
Andreas

----- Forwarded message -----

From: "Vallas Haris" <vallas@neon-energy.com>  
Date: 8 Nov 2016 22:56  
Subject: Fwd: RE: KEYSTONE  
To: "Ανδρέας" <andreas.georgakis@gmail.com>  
Cc:

Haris Vallas  
President,  
Aluminum Division

C: 516 348 3526  
C: 949 332 9747  
E:vallas@neon-energy.com

18101 Von Karman Avenue  
Suite 1930, Irvine, CA 92612

----- Προωθημένο μήνυμα -----

Από: Jon Hill <[jhill@keystonecerts.com](mailto:jhill@keystonecerts.com)>

Ημερομηνία: 8 Νοε 2016 9:51 μ.μ.

Θέμα: RE: KEYSTONE

Προς: Vallas Haris <[vallas@neon-energy.com](mailto:vallas@neon-energy.com)>, Alysha Hill <[ahill@keystonecerts.com](mailto:ahill@keystonecerts.com)>

Κοιν.: Georgakis <[a.georgakis@neon-energy.com](mailto:a.georgakis@neon-energy.com)>

Thanks Vallas,

I just wanted to mention that the company name specified on the License Agreement is the company name that will be specified on all certifications.

If you wanted to, you could specify “Heyward Investments USA, DBA Neon Energy”, we could then issue the certifications under just “Neon Energy” - ?

We are also happy to proceed with company name as “Heywood Investment USA Inc.”.

Let me know your thoughts,

Jon Hill

President

Keystone Certifications, Inc.

564 Old York Rd, Suite 5

Etters, PA 17319

V: 717-932-8500

F: 717-932-8501

This e-mail and any attachment thereto may contain information which is confidential, privileged or otherwise protected from disclosure and/or protected by property rights. It may be read, copied and used only by the intended recipient and is only for the purpose for which it has been sent. If you are not the intended recipient, please contact the sender immediately by return e-mail or by telephoning, and delete this message and any attachment from your system. In such case you must not copy this message or attachment or disclose the contents to any other person. We believe, but do not warrant that this e-mail and any attachments are virus free.

---

**From:** Vallas Haris [<mailto:vallas@neon-energy.com>]  
**Sent:** Tuesday, November 08, 2016 2:19 PM  
**To:** Jon Hill; Alysha Hill  
**Cc:** Georgakis  
**Subject:** Fwd: KEYSTONE

For any further information i am at your disposal...

Best Regards,

Haris Vallas  
President,  
Aluminum Division

C: 516 348 3526  
C: 949 332 9747  
[E:vallas@neon-energy.com](mailto:vallas@neon-energy.com)

18101 Von Karman Avenue  
Suite 1930, Irvine, CA 92612

----- Προωθημένο μήνυμα -----  
Από: Petros Konstantinou <[konstantinou@neon-energy.com](mailto:konstantinou@neon-energy.com)>  
Ημερομηνία: 8 Νοε 2016 8:02 μ.μ.  
Θέμα: KEYSTONE  
Προς: 'Vallas Haris' <[vallas@neon-energy.com](mailto:vallas@neon-energy.com)>  
Κοιν.:

>  
>>  
>>  
>>  
>>  
>>  
>> Best Regards,  
>>  
>>  
>>  
>> Petros Konstantinou  
>>  
>>  
>>  
>>  
>>  
>> CELL: (949) 394-5502  
>>  
>> [konstantinou@neon-energy.com](mailto:konstantinou@neon-energy.com)  
>>  
>> [www.neon-energy.com](http://www.neon-energy.com)  
>>  
>>



# NATIONAL CERTIFIED TESTING LABORATORIES

FIVE LEIGH DRIVE • YORK, PENNSYLVANIA 17406 • TELEPHONE (717) 846-1200  
FAX (717) 767-4100  
www.nctlinc.com

**AAMA/WDMA/CSA 101/I.S.2/A440-08**

## TEST REPORT SUMMARY

**Rendered to:**

**NEON ENERGY  
230 Park Avenue 10<sup>th</sup> Floor  
New York, NY 10169**

**PRODUCT TYPE: Fixed Lite**

**SERIES/ MODEL: "Fixed"**

Title	Summary of Results
Primary Product Designator AAMA/WDMA/CSA 101/I.S.2/A440-08	Class CW-PG30: Size tested 1524 x 2515 mm (60 x 99 in) - Type FW
Design Pressure	±1440 Pa (±30.0 psf)
Air Infiltration	0.1 L/s/m <sup>2</sup> (<0.01 cfm/ft <sup>2</sup> )
Water Penetration Resistance Test Pressure	440 Pa (9.0 psf)
Uniform Load Structural Test Pressure	±2160 Pa (±45.0 psf)
Forced Entry Resistance	ASTM F588-07 - Grade 10 Pass

Test Completed: 08/03/16

Reference must be made to Report No. NCTL-110-19251-2 dated 08/05/16 for complete test specimen description and data.

**For National Certified Testing Laboratories**

Jay Leader  
Technician



# ***NATIONAL CERTIFIED TESTING LABORATORIES***

FIVE LEIGH DRIVE • YORK, PENNSYLVANIA 17406 • TELEPHONE (717) 846-1200  
FAX (717) 767-4100  
www.nctlinc.com

**AAMA/WDMA/CSA 101/I.S.2/A440-08**

## **STRUCTURAL TEST REPORT**

**NCTL-110-19251-2**

REPORT TO:

NEON ENERGY  
230 PARK AVENUE 10<sup>TH</sup> FLOOR  
NEW YORK, NY 10169

REPORT NUMBER: NCTL-110-19251-2  
REPORT DATE: 08/05/16

**PRODUCT TYPE: FIXED LITE**

**SERIES/ MODEL: "FIXED"**



# NATIONAL CERTIFIED TESTING LABORATORIES

FIVE LEIGH DRIVE • YORK, PENNSYLVANIA 17406 • TELEPHONE (717) 846-1200  
FAX (717) 767-4100  
www.nctlinc.com

**Report Number** NCTL-110-19251-2  
**Report Date** 08/05/16  
**Report To** Neon Energy  
230 Park Avenue 10<sup>th</sup> Floor  
New York, NY 10169  
**Date Testing Started** 07/18/16  
**Date Testing Completed** 08/03/16  
**Specification** AAMA/WDMA/CSA 101/I.S.2/A440-08  
NAFS North American Fenestration Standard/Specification for windows,  
doors, and skylights  
**Performance Results** AAMA/WDMA/CSA 101/I.S.2/A440-08  
Class CW-PG20: Size tested 1524 x 2515 mm (60 x 99 in)-Type FW

## ***Description of Specimen Tested***

Note: All dimensions are in the order (Width x Height x Thickness) unless otherwise noted.

**Model/ Series** Fixed  
**Configuration** Fixed Lite  
**Frame Size** Overall  
1524 mm x 2515 mm (60" x 99")  
**Viewing Area** 1422 mm x 2413 mm (56" x 95")  
**Frame Type** Extruded aluminum with polyamide thermal break  
**Joint Construction** Frame  
Mitered, with epoxied with aluminum staked-in-place and epoxied corner gusset  
**Glazing Components**  
Overall 22.23 mm (0.875") nominal  
Glass Thickness (1) Lite of 6 mm (0.230") nominal tempered glass to the exterior and (1) lite of 6 mm (0.230") nominal annealed glass to the interior  
Spacer Type/Size 10.54 mm (0.415") Desiccant-filled stainless steel spacer (Type SS-D)  
Glazing System Interior glazed against a multi-fin vinyl glazing gasket and a snap-in extruded aluminum glazing bead with a flexible vinyl wedge gasket  
**Weatherstrip**  
Type Bulb-vinyl gasket  
Location Sill  
**Operating Hardware** No operating hardware employed  
**Auxiliary** No auxiliary items employed  
**Reinforcement** No reinforcement employed

**Weep Description**

Size 25.4 mm (1") wide by 7.95 mm (0.313") high with plastic weep cover  
 Location 136.53 mm (5.375") from each end and midspan of the exterior sill face

**Interior/ Exterior  
Surface Finish**

White painted aluminum

**Sealant**

Location 152.4 mm (6") High heel bead employed at bottom of jambs  
 Material Silicone

**Insect Screen**

No screen employed

**Installation Method**

The window was installed in a 50.8 mm x 254 mm (2" x 10") spruce-pine-fir lumber test buck and secured with (1) #8 x 38.1 mm (1.5") pan head screw located at 50.8 mm (2") and 559 mm (22") from each end of the sill and head; 50.8 mm (2"), 559 mm (22"), 1067 mm (42"), 1702 mm (67"), 2197 mm (86.5") and 2464 mm (97") from the bottom of each jamb. The exterior perimeter was sealed with silicone sealant.

**Test Results - AAMA/WDMA/CSA 101/I.S.2/A440-2008**

Paragraph  
5.3.2.1/ 9.3.2

Test  
Air Leakage Resistance  
ASTM E283-04(12)

The tested specimen meets or exceeds the performance levels specified in AAMA/WDMA/CSA 101/I.S.2/A440-2008 for air infiltration at 75 Pa (1.6 psf).

Maximum Allowable	=	1.5 L/s/m <sup>2</sup> (0.3 cfm/ft <sup>2</sup> )
Extraneous Air Leakage	=	0.93 L/s (1.97 cfm)
Total Air Leakage	=	1.17 L/s (2.47 cfm)
Air Infiltration Rate	=	0.1 L/s/m <sup>2</sup> (<0.01 cfm/ft <sup>2</sup> )

Paragraph  
5.3.3/ 9.3.3

Test  
Water Penetration Resistance  
ASTM E547-00(09)

3.4 L/ (min • m<sup>2</sup>) (5.0 gph/ft<sup>2</sup>)

No Leakage after 4 cycles of 5 minutes at 440 Pa (9.0 psf)

**NOTE:** Tested without insect screen

Paragraph  
5.3.4.2

Test  
Uniform Load Deflection at Design Pressure  
ASTM E330-14

No damage after positive	1440 Pa (30.0 psf) held for 10 seconds
No damage after negative	1440 Pa (30.0 psf) held for 10 seconds
Measured Deflection <sup>Positive</sup>	= 0.94 mm (0.037 inches)
Measured Deflection <sup>Negative</sup>	= 1.52 mm (0.060 inches)
Maximum Allowed (L/175)	= 14.38 mm (0.566 inches)

Paragraph  
5.3.4.3

Test  
Uniform Load Structural Test  
ASTM E330-14

No damage after positive      2160 Pa (45.0 psf) held for 10 seconds  
 No damage after negative      2160 Pa (45.0 psf) held for 10 seconds

Measured Permanent Set <sub>Positive</sub> = 0.28 mm (0.011 inches)  
 Measured Permanent Set <sub>Negative</sub> = 0.74 mm (0.029 inches)  
 Maximum Allowed (0.3%)      = 7.54 mm (0.297 inches)

**NOTE:** Deflection and Permanent Set measurements taken on the jamb over a 2515 mm (99") span.

Paragraph  
5.3.5/ 9.3.5

Test  
Forced Entry Resistance  
ASTM F588-07

Type D Window Assembly/ Grade 10: = Pass

Test  
Disassembly                      = No Entry  
 Sash Manipulation              = No Entry

**NOTE:** 1. T1 = 5 minutes, L1 = 667 N (150 lbf), L2 = 333 N (75 lbf), L3 = 111 N (25 lbf)  
 2. Loads were held for 60 seconds.

This test report was prepared by National Certified Testing Laboratory (NCTL), for the exclusive use of the above named client and it does not constitute certification of this product. The results are for the particular specimen tested and do not imply the quality of similar or identical products manufactured or installed from specifications identical to the tested product. The test specimen was supplied to NCTL by the above named client. No conclusions of any kind regarding the adequacy or inadequacy of the glass in the test specimen are to be drawn from the ASTM E330 test. Forced entry resistance test equipment used is in compliance with Section 7 of the ASTM F588-07 test method. Foam tape is mounted to the perimeter of the test buck prior to clamping to the test wall. It is the assertion of this laboratory that any film employed during testing does not affect measurement values. NCTL is a testing lab and assumes that all information provided by the client is accurate and does not guarantee or warranty any product tested or installed. The results in this report are actual tested values and are applicable to the specimen tested only, using the components and construction methods described herein.

Detailed drawings were available for laboratory records and compared to the test specimen at the time of this report. Component drawings were reviewed for product verification. The bill of materials contains details with any deviations noted. Ambient conditions during the referenced testing are available upon request. A copy of this report along with representative sections of the test specimen will be retained per applicable requirements by NCTL. This report does not constitute certification or approval of the product, which may only be granted by a certification program validator or recognized approval entity. All tests were conducted in full compliance with the referenced specifications and/or test methods. Tests were performed in the order set forth by the applicable standard or specification. This report is the joint property of National Certified Testing Laboratories Inc. and the Client to whom it is issued. Permission to reproduce this report by anyone other than National Certified Testing Laboratories Inc and the Client must be granted in writing by both of the above parties. This report may not be reproduced, except its entirety, without the written consent of NCTL.

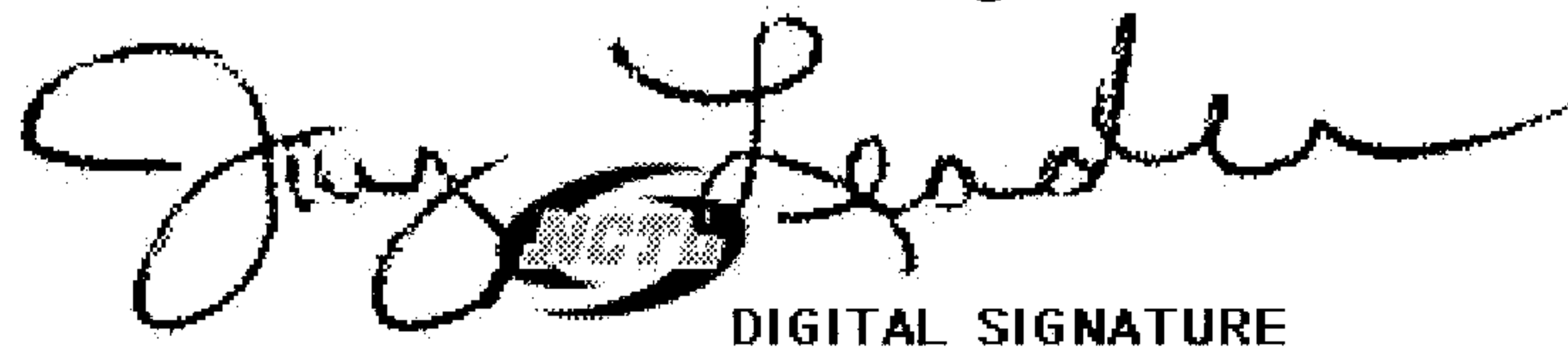
**National Certified Testing Laboratories**A handwritten signature in cursive script that reads "Jay Leader". The signature is written in black ink and is positioned above the text "DIGITAL SIGNATURE".

Jay Leader  
Technician

A handwritten signature in cursive script that reads "R. H. Zeiders". The signature is written in black ink and is positioned above the text "DIGITAL SIGNATURE".

Robert H. Zeiders, P.E.  
Vice-President Engineering & Quality

NJL/ dro

Attachments

Appendix A – Revision Summary

Appendix B – Drawings

**Appendix A**  
**Revision Log**

<u>Identification</u>	<u>Date</u>	<u>Page &amp; Revision</u>
Original Issue	08/05/16	Not Applicable

## **Appendix B**

### **Drawings**

Component Drawings, with Applicable Part Numbers, Manufacturing and Modeling Details, were reviewed (as submitted) for Product Verification. Detailed assembly drawings showing wall thicknesses of all members, corner construction and hardware application are on file and have been compared to the test sample submitted.  
(Reference: NCTL-110-19251-2)

See Attached Documentation;  
any deviations noted.

Note: The above referenced component drawings (if applicable) along with representative sections of the test specimen will be retained by NCTL per applicable retention requirements. This testing facility assumes that all information provided by the client is accurate.

**Description of test specimen No 5 & No 6:**

Product	Fixed window
Manufacturer	Alco Hellas S.A.
Date of manufacture	3/6/2016
System	Ultra 2016 Opening System
Type of opening / Opening directions	No opening
Frame material	Aluminum profiles with thermal break
Overall frame dimensions (WxH)	5' 0" x 8' 3"
<b>Frame member</b>	Profile No TVO 921
Frame joint	mitred, compressed and bonded with corner connection No GS 56-80 and GS 152-186
<b>Infill panel</b>	Glass Unit
Configuration	from inside to outside: 15/64" glass, 35/64" airspace, 15/64" glass
<b>Incorporation of infill panel</b>	
<b>Glazing gasket</b>	
<u>Internal:</u>	
Material	Sealing material – EPDM
Item No	P3
Corner design	mitred and bonded
<u>Glazing bead</u>	Profile No VO 41
Corner design	butt-jointed
Fixing	clamped
<u>External:</u>	
Material	Sealing material – EPDM
Item No	AVO-03
Corner design	mitred and bonded

TEST SPECIMEN COMPLIES  
WITH THESE DETAILS.  
ANY DEVIATION IS NOTED  
REPORT NO. NCTL-110- 19251-2  
TEST DATE 8/3/16

**HORIZONTAL SECTION A-A' & VERTICAL SECTION BB'**

**KA. 1:1**

**TEST SPECIMENT No 5 & No 6**

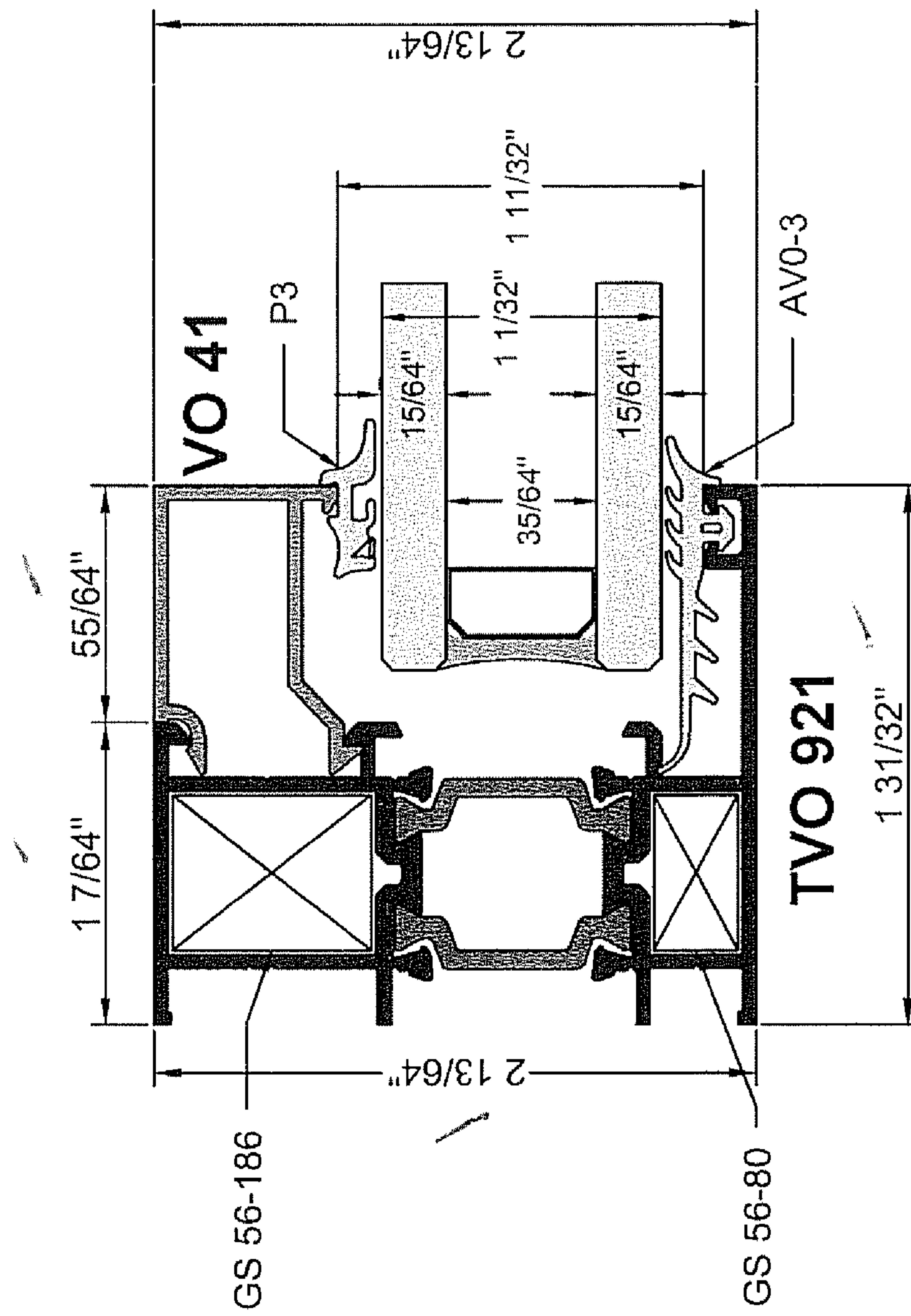
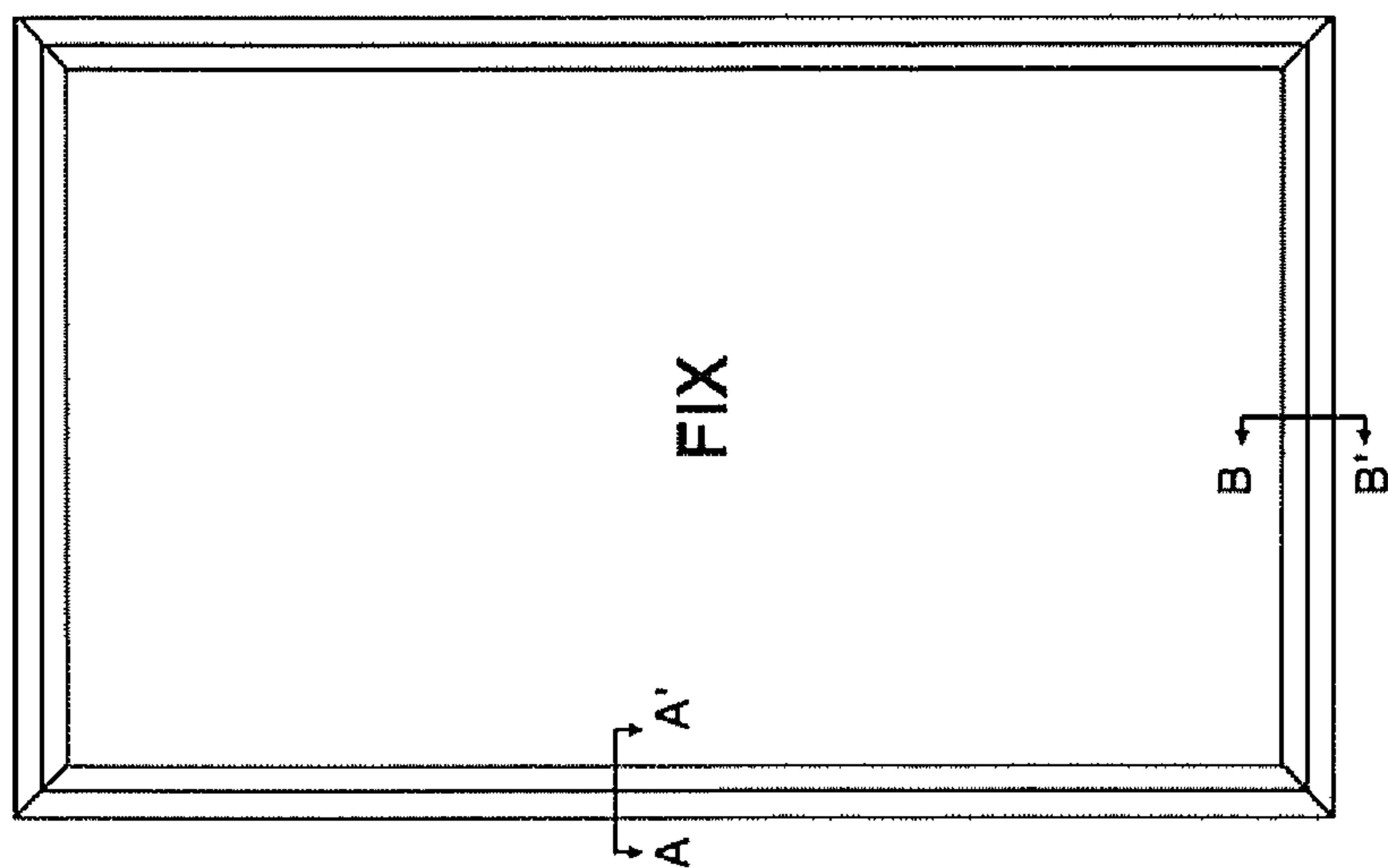

TEST SPECIMEN COMPLIES  
 WITH THESE DETAILS.  
 ANY DEVIATION IS NOTED  
 REPORT NO. NCTL-110-19251-2  
 TEST DATE 8/3/16